

## NEW HAMPSHIRE FISH AND GAME DEPARTMENT

### DECEMBER 19, 2023 COMMISSION MEETING MINUTES

Meeting Location: NH Fish & Game Department, 11 Hazen Drive, Concord, NH 03301.

Commissioners Present: M. Hodgson, J. Caveney, R. Green, B. Temple, E. Stohl, S. Price, J. Titone, C. Hodgdon, P. DeBow & A.J. DeRosa.

Commissioners absent/excused:

Belknap County Commissioner seat is vacant at this time.

Executive Director Mason – Present

Chairman E. Stohl called the meeting to order at 1:00 p.m., and asked the audience to join in the pledge of allegiance. He informed the audience that the public is entitled to attend all Commission meetings and when recognized by the Chairman, the public may speak on any item on the agenda. The Chairman reserves the right to limit comment to the extent necessary for the orderly conduct of the meeting.

#### **ACTION ITEMS:**

1.) Commissioner R. Green moved to approve the November 14, 2023 Commission Minutes and Commissioner J. Caveney seconded. The vote was unanimous in the affirmative.

1a.) Presentation of the 2022 Commission Awards of Excellence –

Commissioner A.J. DeRosa, Chair, Public Engagement & Education Committee, stated that the public plays an essential part in helping the Department fulfill its mission. He encouraged people to nominate worthy individuals for the various important Commission Awards. The nomination forms and award categories are on the Department's website.

He further reported that Commissioner Paul DeBow would be presenting the Youth Conservationist Award of Excellence. Commissioner DeBow asked Ezra McGinley-Smith, Hanover, of NH, to join him at the podium. He stated, "It makes me happy to see young adults enjoying all that nature has to offer". He reported that Ezra is a talented photographer, filmmaker and outdoor enthusiast. Ezra created a video telling the Hanover Conservancy's story, the oldest land trust in New Hampshire, as part of their 60<sup>th</sup> Anniversary. In addition to this, he has worked to improve fish habitat and riverfront protection on the Connecticut River. Wearing a wetsuit, Ezra has hauled endless pounds of trash and debris from the river on his own time.

On behalf of the Commission, Commissioner DeBow congratulated Ezra on his accomplishments and for receiving the award.

Commissioner A.J. DeRosa presented the Habitat Stewardship Award of Excellence to Paul Wainwright, Chair, of the Atkinson Conservation Commission.

Commissioner DeRosa reported that Paul was nominated by a member of the Atkinson Conservation Commission and seems to work full-time, even though he is a volunteer on the Commission. Through partnerships among nonprofits and other organizations, he has endeavored to

acquire, protect, and conserve new lands that benefit the wildlife of New Hampshire. These lands also benefit hunters, outdoor enthusiasts, and the town's natural resources.

On behalf of the Commission, Commissioner DeRosa thanked Paul for his efforts in conserving land and habitat.

Paul thanked the Commission for the award and stated that he did not do this all alone. He reported that he has had a great deal of support from Robert Worden, Selectmen, Town of Atkinson, who is very supportive of conservation in Atkinson, along with Barbara Richter, Executive Director, NH Association of Conservation Commissions, who is a wealth of knowledge and support to all Conservation Commissions.

Major David Walsh, Law Enforcement Division, presented the Search and Rescue Award of Excellence to the New Hampshire National Guard. Major Walsh stated that the NH National Guard is and has always been a significant part of Search & Rescue in New Hampshire. He reported that the NH National Guard rescued stranded residents in Conway, NH, the previous night due to high flooding.

He reported that the NH National Guard has shown infinite dedication to the cause of Search and Rescue across the state, including in the White Mountains. Their commitment and action in the service to citizens who require difficult and/or swift rescue is commendable, according to the Appalachian Mountain Club who nominated them. In addition, he reported that the National Guard Service has also assisted rescuers and prevented them from becoming injured.

On behalf of the Commission, Major Walsh & Commissioner DeRosa thanked the NH National Guard for their continued service and dedication.

Commissioner Ray Green presented the Ellis R. Hatch Jr. Commission Award of Excellence to Robert "Bob" L'Heureux, of Merrimack, NH.

Commissioner Green reported that Robert L'Heureux has spent decades supporting NH Fish and Game and the important work the department does connecting people with the outdoors. He has donated many times to the agency, including to the K-9 program. He served as a Representative in the NH Legislature on the Marine Resources Committee for many years. He also produced a long-running "Outdoors with Bob" show on the Merrimack Community television channel.

Former Representative Larry Guaraldi, Enfield, NH, was present and asked to say a few words about Bob. Larry reported that he served a long time on the Legislature with Bob L'Heureux. He reported that there was no bigger supporter of the Fish & Game Department than Bob. He reported that Bob testified in support of the Commission on numerous bills that came before The House Fish and Game and Marine Resources Committee. In closing he stated, "Well deserved!"

On behalf of the Commission, Commissioner Green thanked Bob L'Heureux for his continued support and contributions to the agency.

Commissioner R. Green moved to accept consent agenda items 2a. – 2f., as presented below, Commissioner J. Caveney seconded.

- 2a.) The Commission accepted the donation of \$50.00 from Paul & Susan Henkel, Keene, NH, deposited into the Small Gifts & Donations Account, for use by the Nongame Program.
- 2b.) The Commission accepted the donation of \$500.00 from James & Elizabeth Wavle, Moultonborough, NH, deposited into the Small Gifts & Donations Account, for use by the Nongame Program.
- 2c.) The Commission accepted the donation of \$100.00 from the Milford Garden Club, for use by the Conservation Education Program.
- 2d.) The Commission accepted the donation of \$20.00 from Margaret Kilrain, Manchester, NH, deposited in to the Small Gifts & Donations Account.
- 2e.) The Commission accepted the donation of \$200.00 from Frank Dubisz, deposited into the Operation Game Thief Account, to go towards the purchase of a deer decoy.
- 2f.) The Commission accepted the donation of \$50.00 from the NH Trappers Association, to go towards the purchase of live saving equipment that would not otherwise be possible due to budget constraints.

The vote was unanimous in the affirmative to accept the above consent agenda items.

**INFORMATION ITEMS:**

- 1.) There were no questions for Kathy LaBonte, Chief, Business Division, regarding the monthly financial statement.
- 2.) Dianne Timmins, Chief, Inland Fisheries Division, came before the Commission and provided a thorough update on the Hatchery Modernization Project, to include estimates and a timeline.

## New Hampton 150,000 lb Concept



## Proposed Summary of Production (lbs) by Facility

Hatchery	Existing	Proposed
Powder Mill	124,097	30,000
Berlin	74,336	64,336
New Hampton	71,792	150,000
Milford	68,124	68,124
Twin	20,698	23,000
Warren	26,742	26,742
<b>Total</b>	<b>358,789</b>	<b>362,202</b>

## Long-Term Plan

- Phase 1 - 2025:
  - Powder Mill – Reduction in annual production from 118,000 lbs to 30,000 lbs (75% reduction) to meet effluent TP limits.
- Phase 2 - 2026:
  - New Hampton – New RAS facility to accommodate 150,000 lbs in production plus house Brook and Brown Trout broodstock.
- Phase 3 - 2027:
  - Twin Mountain – Reduction in production to less than 15,000 lbs, focus on Rainbow Trout broodstock.
- Phase 4 - 2028:
  - New Hampton Phase 2A -- With additional funding, this facility could produce up to 250,000 lbs with minimal rearing improvements, and effluent discharge relocation to the Pemigewasset River.
- Phase 5 - 2029:
  - Reevaluation of the statewide system will likely be necessary at this time to determine the best way to meet production goals. A combination of the options below will likely be required. These improvements have not yet been estimated given it is unknown which options will be required.
    - Berlin – Reduction in annual production from 74,000 lbs to roughly 64,000 lbs (13.5% reduction). If further reduction is deemed necessary after receiving the final EPA discharge permit this facility will shift its focus to Brook Trout broodstock only as a viable alternative to meet new effluent TP limits.
    - Milford – Continue operation with investment in rehabilitation of existing infrastructure if required to meet production goals.
    - Warren – Continue operation with investment in rehabilitation of existing infrastructure if required to meet production goals.

# Recirculating Aquaculture System 101

- ❖ Extensively used in fish hatcheries
- ❖ More efficient operation, saves costs
- ❖ Enclosed environment, reuses most of the water
- ❖ Less water treatment per gallon (effluent discharge)
- ❖ Controlled environment and improved water quality
- ❖ Increase production and remain compliant with EPA (NPDES permit)
- ❖ Individualized filtration and on/off valves
- ❖ Monitoring and control of water quality parameters
- ❖ Management practices to deal with disease or any other emergency situation

## Example of RAS Facility

### KEYED NOTES:

- 1 OFFICES AND STAFF CUBICLET SPACES IN INSULATED PRE-ENGINEERED BUILDING
- 2 EGG INCUBATION ROOM INCLUDING BIOSECURITY EGGS RASH AREA, VERTICAL FLOW EGG INCUBATORS AND CIRCULAR FEED TRAINING TANKS. THIS ROOM ON FLOOR THROUGH WALKER LAB ONLY (NOT RAS.)
- 3 WATER SUPPLY LINE FOR MAKEUP WATER TO THE RAS SYSTEM
- 4 PROCESS MECHANICAL ROOM
- 5 20-FT DIAMETER INTERMEDIATE REARING TANKS WITH MODULAR RAS TREATMENT COMPONENTS. TWO (2) RAS MODULES WITH 10 TANKS PER MODULE. TANKS ARE DUAL DRAIN DESIGN.
- 6 40-FT DIAMETER FINAL GROW-OUT TANKS WITH MODULAR RAS TREATMENT COMPONENTS. FOUR (4) RAS MODULES WITH 4 TANKS PER MODULE. TANKS ARE DUAL DRAIN DESIGN.
- 7 GENERAL EQUIPMENT STORAGE SPACE
- 8 FEED STORAGE SPACE (AIR CONDITIONED)
- 9 ELECTRICAL EQUIPMENT ROOM - ELECTRICAL PANELS AND EMERGENCY ELECTRICAL GENERATOR. PROCESS MONITORING AND INSTRUMENTATION SYSTEM FOR ALL RAS MODULES PROVIDED.
- 10 PRE-ENGINEERED INSULATED METAL BUILDING WITH HVAC SYSTEMS. BUILDING SIZE IS APPROXIMATELY 90,700 SQUARE FEET.
- 11 RAS MODULES PROVIDED - EACH MODULE INCLUDES DUAL DRAIN CULTURE TANKS, MICROSCREEN, CIRCULATION PUMPS, GROSS TREATMENT TOWER, GAS MANAGEMENT TOWER WITH CO<sub>2</sub> & O<sub>2</sub> GAS MANAGEMENT, UV DISINFECTION, CO<sub>2</sub> AND SYSTEM DRAIN. SYSTEM IS WITH RECIRCULATION-TYPE MAKE-UP BY RATE OF FLOW RAS DESIGN. RAS MODULES CAN OPERATE AS STAND-ALONE RECYCLING SYSTEMS.

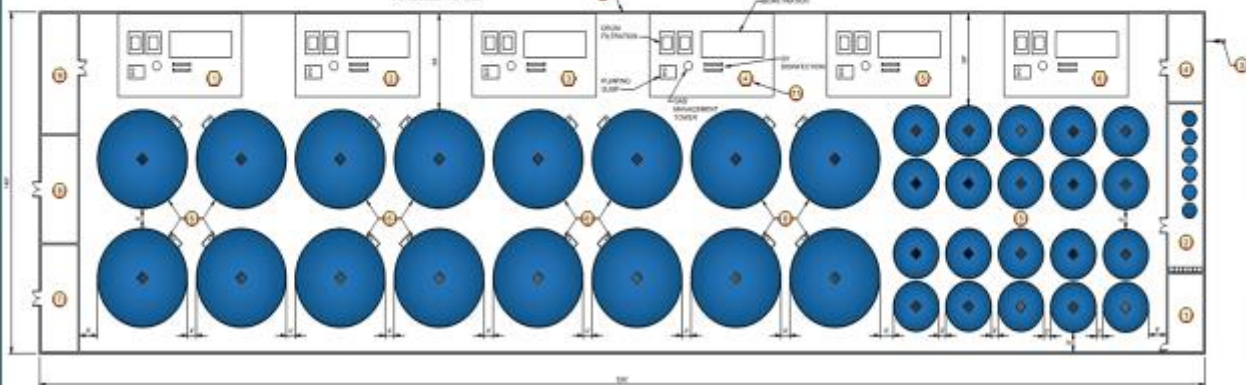

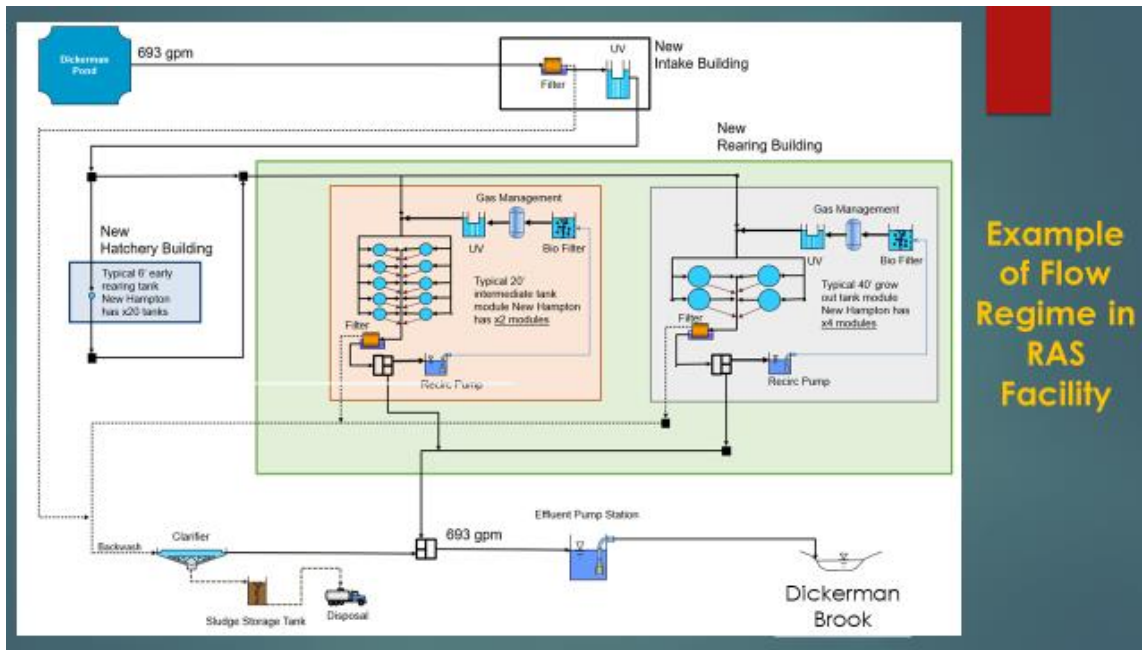

Example of Flow Regime in RAS Facility

### Hatchery Building Conceptual Layout

- 9,600+ SF Building with conditioned office areas
- 30 Early Rearing tanks @ 6' dia – allows for fish to 3"
- 6 Broodstock Tanks @ 10' dia
- 2 Linear Spawning raceways (interment use)
- First use Dickerman Pond water 652 gpm

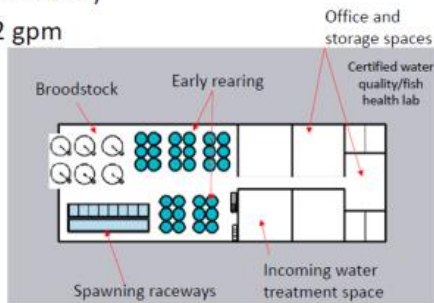

### Intermediate Building Conceptual Layout

- Pavilion style cover – 16,000 sf building
- 18 Rearing tanks @ 20' dia – 3" to 6" Fish
- Dual drain tanks
- 95% RAS treatment building
- Flow rate 3,172 gpm Total (3,014 gpm RAS with 159 gpm makeup)

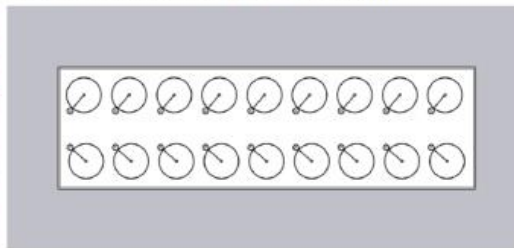

# Growout Building Conceptual Layout

- Tension fabric structure building or pavilion style building (60,000 sf)
- 20 Rearing tanks @ 40' dia – 6" fish to target
- Dual drain tanks
- 95% RAS
- Flow 12,533 gpm (11,906 gpm RAS with 627 gpm makeup)

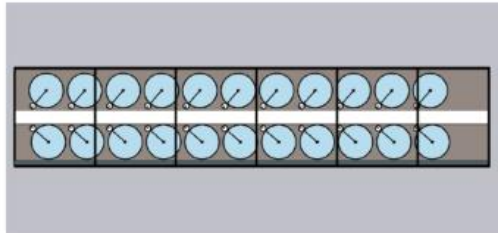

**Updated Estimate**  
11/2023

**New 95% RAS Facility  
at New Hampton**

**150,000lbs**

ESTIMATED EXPENSE:

HDR Design contract	\$ 7,253,000.00
DPW Oversight	\$ 500,000.00
Construction	\$47,700,000.00
Construction Mgr at Risk	TBD* may be in costs
	<b>\$55,453,000.000</b>

Opinion of Probable Construction Cost Summary		
Alternative 1A - Phase 2B		EXTENSION
<b>A. Aquaculture Water Supply</b>		
A1 Hatchery Supply		\$176,900
<b>B. Buildings and Rearing Units</b>		
B1 Intake Building		\$1,138,100
B2 Hatchery Building		\$3,029,600
B3 Rearing Building		\$14,177,900
B4 Rehabilitation/Demo of other buildings on site		\$283,800
<b>C. Site</b>		
C1 Site Work		\$598,400.00
C2 Domestic Water		\$35,600.00
C3 Domestic Wastewater		\$71,200.00
C4 Disinfection Station		\$16,200.00
C5 Paved Access to State or Local Highways		\$270,600.00
<b>D. Aquaculture Wastewater</b>		
D1 Effluent Treatment		\$1,472,600
D2 Effluent Monitoring		\$46,400.00
<b>E. Electrical and HVAC</b>		
E1 Electrical Service		\$215,000.00
E2 Emergency Power		\$326,200.00
E3 Instrumentation and Alarm System		\$284,800.00
<b>F. Visitor Education/Interpretation</b>		
F1 Visitor Center Repairs		\$429,900.00
	<b>Subtotal</b>	<b>\$22,572,600</b>
Contractor's Field General Conditions	10%	\$ 2,257,000
Contractor's Mobilization	2%	\$ 497,000
Contractor's Overhead and Profit	10%	\$ 2,533,000
Bonds and Insurance	2%	\$ 557,000
<b>Subtotal - Contractor Costs</b>		<b>\$ 28,416,600</b>
Contingency	44%	\$ 12,390,000
<b>Subtotal</b>		<b>\$ 40,806,600</b>
Escalation to Midpoint of Const. (2026)	11%	\$ 4,666,000
Market Volatility Adjustment Factor	5%	\$ 2,274,000
	<b>Grand Total</b>	<b>\$ 47,700,000</b>

DESIGN & CONSTRUCTION TIMELINE

**DPW Timeline  
for  
Project**

Step	Date	Task
1.	AUG 2023	Proposal from HDR for design and construction
2.	DEC 2023	G&C approval of HDR agreement
3.	JAN 2024	Issue RFP for Construction Manager (CM)
4.	MAR 2024	30% design submission for review by NHFG, DPW & CM
5.	APR 2024	Shortlist Construction Manager
6.	MAY 2024	Construction Manager provide Guaranteed Maximum Price
7.	AUG 2024	G&C approval for Construction Manager
8.	SEP 2024	60% design submission for review by NHFG, DPW & CM
9.	DEC 2024	90% design submission for review by NHFG, DPW & CM
10.	JAN 2025	100% design and bid documents
11.	FEB 2025	Begin construction
12.	DEC 2026	Contracts completed

On behalf of the Commission, Chairman Stohl thanked Dianne for the informative update.

Dianne responded that she would keep the Commission updated on this project.

**COMMITTEE STRUCTURE:**

**LEGISLATIVE COMMITTEE:** Public policy development & recommendations, as well as Commission advocacy before legislature.

**Commissioner Price, Chair;** Commissioners: Caveney, DeBow, Hodgson & Green.

**Staff members:** Kevin Jordan & Marty Mobley.

Commissioner S. Price reported that the committee met the morning of the Commission Meeting and discussed the following legislation:

Commissioner S. Price moved to support HB-1002, relative to fees for records under The Right-to-Know Law and Commissioner P. DeBow seconded. The vote was unanimous in the affirmative.

Commissioner R. Green moved to oppose HB-1100, relative to coyote hunting and Commissioner J. Caveney seconded. The vote was unanimous in the affirmative.

Commissioner R. Green moved to oppose HB-1424, relative to pistols permitted for taking of game and Commissioner S. Price seconded. The vote was unanimous in the affirmative.

Commissioner S. Price moved to oppose HB-1116, relative to certain firearms to be used for taking of game and Commissioner P. DeBow seconded. The vote was unanimous in the affirmative.



Commissioner S. Price moved to oppose HB-1143, relative to including control of cyanobacteria blooms under the NH Clean Lakes Act and Commissioner P. DeBow seconded. The vote was unanimous in the affirmative.

Commissioner S. Price moved to oppose HB-1148, relative to the Fish and Game Commission and Commissioner P. DeBow seconded. The vote was unanimous in the affirmative.

Commissioner S. Price moved to oppose CACR-15, relative to taxation and Commissioner P. DeBow seconded. The vote was unanimous in the affirmative.

Commissioner S. Price moved to support HB-1304, relative to vessel registration and boat fee decals and Commissioner P. DeBow seconded. The vote was unanimous in the affirmative.

Commissioner S. Price moved to oppose HB-1558, relative to Agent fees for Fish and Game Licenses and Commissioner P. DeBow seconded. The vote was unanimous in the affirmative.

Commissioner S. Price moved to oppose HB-1024, relative to the use of air rifles for hunting game and Commissioner P. DeBow seconded. The vote was unanimous in the affirmative.

Commissioner S. Price moved to oppose HB-1026, relative to resisting arrest and Commissioner P. DeBow seconded. The vote was unanimous in the affirmative.

Commissioner S. Price moved to oppose HB-1029, relative to exempting certain persons from requiring a NH Landing License if such persons are not landing for the purpose of the sale of the lobster or crab they have caught and Commissioner P. DeBow seconded. The vote was unanimous in the affirmative.

Commissioner S. Price moved to oppose HB-1069, relative to material subject to disclosure following a public meeting under the Right-to-Know Law and Commissioner P. DeBow seconded. The vote was unanimous in the affirmative.

Commissioner S. Price moved to oppose with HB-1417, relative to wild brook trout management and Commissioner P. DeBow seconded. The vote was unanimous in the affirmative.

Commissioner S. Price move to oppose HB-1420, relative to communications between agencies and citizens and Commissioner P. DeBow seconded. The vote was unanimous in the affirmative.

Commissioner S. Price moved to oppose HB-1325, relative to allowing private ownership of small- tailed monkeys, raccoons, foxes, otters, skunks, and kangaroos (no permit required) and Commissioner P. DeBow seconded. The vote was unanimous in the affirmative.

Commissioner S. Price moved to oppose HB-1532, relative to landowner rights and responsibilities pertaining game cameras and tree-stands and Commissioner P. DeBow seconded. The vote was unanimous in the affirmative.

Commissioner S. Price moved to oppose HB-1530, relative to requiring Fish and Game Officers to wear body cameras and Commissioner P. DeBow seconded. The vote was unanimous in the affirmative.

Commissioner S. Price moved to oppose HB-1121, relative to creating certain wetlands permit exemptions after a natural disaster or flooding event. The vote was unanimous in the affirmative.

Commissioner S. Price moved to oppose HB-1527, relative to criminal trespass and Commissioner P. DeBow seconded. The vote was unanimous in the affirmative.

Commissioner S. Price moved to oppose HB-1521, relative to requiring agencies to respond to issues raised by the public during the rulemaking process and Commissioner P. DeBow seconded. The vote was unanimous in the affirmative.

Commissioner S. Price moved to oppose HB-1228, relative to establishing a Fish and Game Guides Committee to determine the qualifications for Licensure of Fish and Game Guides and Commissioner P. DeBow seconded. The vote was unanimous in the affirmative.

Commissioner S. Price moved to oppose HB-1494, relative to OHRVs and Commissioner P. DeBow seconded. The vote was unanimous in the affirmative.

Commissioner S. Price moved to oppose HB-1503, relative to the definitions of wetlands and Commissioner P. DeBow seconded. The vote was unanimous in the affirmative.

Commissioner S. Price moved to oppose HB-1484, relative to current use taxation forested lands and Commissioner P. DeBow seconded. The vote was unanimous in the affirmative.

Commissioner S. Price moved to support HB-1138, relative to equalizing the fines for operating an OHRV with a driver's license suspended and operating a snowmobile with a driver's license suspended, Commissioner P. DeBow seconded. The vote was unanimous in the affirmative.

Commissioner S. Price moved to oppose SB-336, relative to misrepresentation by state employees and Commissioner P. DeBow seconded. The vote was unanimous in the affirmative.

Commissioner S. Price moved to oppose SB-542, relative to appointments to the Fish and Game Commission and Commissioner P. DeBow seconded. The vote was unanimous in the affirmative.

Commissioner S. Price moved to support SB-503, relative to requiring a criminal background check when applying for a Fish and Game Guide License and Commissioner P. DeBow seconded. The vote was unanimous in the affirmative.

Commissioner S. Price moved to support SB-310, relative to bear registration and Commissioner P. DeBow seconded. The vote was unanimous in the affirmative.

Commissioner S. Price moved to oppose SB-390, relative to defining "critical habitat" and Commissioner P. DeBow seconded. The vote carried with 9 in favor, 1 opposed (C. Hodgdon).

Commissioner S. Price moved to oppose SB-533, relative to physical quorums at public meetings and Commissioner P. DeBow seconded. The vote was unanimous in the affirmative.

Commissioner S. Price moved to support SB-544, relative to replacing the deer seal system with a confirmation number system and Commissioner P. DeBow seconded. The vote was unanimous in the affirmative.

Commissioner S. Price moved to oppose SB-548, relative to removing gray squirrels from the definition of game animals and Commissioner P. DeBow seconded. The vote was unanimous in the affirmative.

Commissioner S. Price moved to oppose HB-1697, relative to suspending NH's participation in emissions reduction credit programs for a period of 2 years and Commissioner P. DeBow seconded. The vote was unanimous in the affirmative.

Commissioner S. Price moved to oppose SB-346, relative to prohibiting the use of dogs while hunting coyotes and Commissioner A. J. DeRosa seconded and stated, "As long as I'm on this board, I will always support hunting with dogs."

Commissioner P. DeBow stated, "This is way too broad".

Director Mason reminded the Commission that in the recent coyote presentation provided by the Wildlife Division, the department also had some recommendations as to gathering additional information on the coyote take in New Hampshire. He stated that he felt it would be premature to support this bill at this time, until the additional information is gathered and reviewed.

Commissioner C. Hodgdon asked Law Enforcement what challenges this bill could present.

Colonel Jordan responded that it would require Conservation Officers to prove that a dog was actively on the hunt. He stated, "There is already a lot of that type of legislation that requires that now, which is all challenging, however, we are doing it now for other species".

Dan Bergeron, Chief, Wildlife Division, responded that he mirrors what the Director said, that the department is looking to require reporting on the take of any furbearer species, which will ultimately provide the department with more valuable data.

Commissioner M. Hodgson stated, "I appreciate the input from Director Mason and Dan Bergeron regarding additional data on furbearer harvest. I know we have talked about it a few times. Is that a commitment? That there will be data collection?"

Dan responded, "Yes, we will be moving forward with rules for putting together a system to register these animals, all furbearers harvested through hunting".

Commissioner M. Hodgson inquired as to a timeframe.

Dan responded that it would most likely be for the next biennial rulemaking season for game species.

The vote to oppose SB-346 relative to prohibiting the use of dogs while hunting coyotes was unanimous in the affirmative.

Commissioner R. Green moved to readopt with amendments Fis.1204.02 & 1204.03 – Youth Deer and Turkey Hunting Days; expiring in June; add link to on-line Tag; add clarifying language; update citations; Commissioner S. Price seconded. The vote was unanimous in the affirmative. The hearing date is January 19, 2024.

**GOVERNANCE COMMITTEE:** Commission professional development, education & policy recommendations related to Commission conduct & activities.

**Commissioner Caveney, Chair;** Commissioners: Temple, Hodgson & Titone.  
**Staff member:** Cheri Patterson.

Commissioner J. Caveney reported that the committee did not meet.

**SUSTAINABILITY & STRATEGIC PLANNING:** Agency funding, development & oversight of strategic plan.

**Commissioner Hodgdon, Chair;** Commissioners: Caveney, DeRosa, Hodgson & Titone.  
**Staff member:** Scott Mason.

Commissioner C. Hodgdon reported that committee met to finalize the draft focus areas of the strategic plan. He reported there were eight focus areas that the agency needs to focus on over the next five years in order to accomplish its mission. He thanked the Commissioners who served on the Strategic Planning Committee for their participation.

Commissioner S. Price thanked the committee for their work and emphasizing the need to focus on obtaining additional funding for the agency and pressing the issue. She stated, “We need money instead of having to do the best we can with what we have.”

Chairman E. Stohl thanked Commissioner C. Hodgdon & committee members for their hard work on developing the Draft Strategic Plan focus areas and stated that he looks forward to moving the plan forward.

At this time, Commissioner M. Hodgson moved to accept the draft strategic plan focus areas below and Commissioner S. Price seconded. The vote was unanimous in the affirmative.

### **DRAFT**

#### **Strategic Planning and Sustainability Committee Strategic Plan Focus Areas December 2023**

##### 1. Fish, Wildlife and Marine Resources

Sustain through active and passive management, and effective law enforcement, New Hampshire’s abundant fish, wildlife and marine resources. Create and maintain habitat to address changing environmental conditions through conservation.

##### 2. Sustainable Funding

Ensure the Department has the necessary personnel, infrastructure and resources. Diversify, enhance and modernize funding sources while seeking to better align revenue sources with costs in a sustainable manner.

### 3. People

The Department strives to be the employer of choice by providing all employees with the training, equipment, workplace culture and resources to allow them to succeed and flourish. A defined and measurable people strategy will allow our people and the department to perform at its best. Communication, among employees including the Director, divisions and the Commission will foster collaboration, respect and excellence.

### 4. Access

Access to New Hampshire's wildlife and wild places on public and private land by anglers, hunters, trappers and those interested in other recreational pursuits is the foundation of the Department's mission. The department will seek to expand incentives for continued access to private lands and seek partnerships and resources to expand access to public land and water. The department must ensure that public lands and waters are accessible to the public throughout the state.

### 5. Analytics

Data and the analytical systems used to inform management decisions are critical to the Department's ability to complete its mission. The expansion and development of analytical systems will allow the Department to accomplish its mission more effectively in such areas as science-based wildlife and habitat management, infrastructure investment, revenue enhancement, public access and public and license holder engagement.

6. Technology Investment in technology throughout every facet of Department operations will create efficiencies, enhance effectiveness, and improve the public and license holders' access and appreciation for New Hampshire's wildlife and wild places. Technology and its useful application can better connect license holders and the public to the work of the Department while enhancing support for the mission. Efficiencies derived from its use are key to the department maximizing available resources.

### 7. Infrastructure

The public, employees and license holders depend on modern, safe and well-maintained Department infrastructure including its facilities, lands and equipment. The Department will focus on planning to improve the allocation of resources between new infrastructure projects, upgrading, and maintaining existing infrastructure while aligning investment with utilization and revenue.

### 8. Communications and engagement

The Department will sustain efforts to drive engagement in the New Hampshire's wildlife and wild places. The Department will expand and focus efforts on recruitment, retention and reactivation of hunting, angling, trapping and shooting sports enthusiasts in a coordinated fashion across divisions. It

will focus on coordination and partnerships, educational resources across skill levels, access and opportunity, outreach and experience and leveraging broad public support to grow participation to foster the next generation's interest

**RESOURCES & INFRASTRUCTURE:** Policy recommendations related to agency infrastructure; including facilities, public access, habitat & wildlife.

**Commissioner Green, Chair;** Commissioners: Caveney, DeRosa & Temple.  
**Staff member:** Dianne Timmins.

Commissioner R. Green reported that the committee did not meet.

**PUBLIC ENGAGEMENT & EDUCATION:** Engagement, partnership, awards, public recognition & education strategies for the public & interest groups.

**Commissioner DeRosa, Chair;** Commissioners: DeBow, Hodgdon & Price.  
**Staff members:** Dan Bergeron, Kevin Jordan & Cheri Patterson.

Commissioner A.J. DeRosa reported that he worked on a second draft of the Commission Information Sheet. He reported that the committee would be meeting in the near future to continue to review the Commission Information Sheet, as it relates to clarifying the Commission's roles and responsibilities.

Commissioner M. Hodgson stated, "Commissioner A.J. DeRosa did a great job kicking of the awards ceremony today!"

Commissioner A.J. DeRosa thanked Tanya for her assistance.

**SEACOAST REPORT:** Commissioner J. Titone reported that there was a public hearing on the striped bass draft addendum #2. The consensus is one fish per day, with a 14% reduction in the commercial quota for the taking of striped bass. He reported that the comment period ends on December 22, 2023, with a final ruling in early 2024.

He reported on HB 442, relative to the removal of derelict fishing gear. He reported that Eric Anderson, of the NH Commercial Fishing Association, has taken it upon himself to produce a survey issued to all licensed lobstermen in the state to get an idea of their fishing efforts and the actual losses they have sustained over the years. He is assembling the data to determine what impacts derelict/abandoned gear have in NH.

**LAKES MANAGEMENT ADVISORY COMMITTEE:** Commissioner Price.

Commissioner S. Price reported that Commissioner A.J. DeRosa represented the Commission in her absence at the last meeting. Commissioner DeRosa reported that the discussion focused around cyanobacteria and its impacts. He further reported that it is a relevant subject for the agency, as it affects anglers, hunting dogs, etc., and is affecting a great deal of waterbodies. In closing, he stated that he would be interested in having someone from DES (Department of Environmental Services) attend a future Commission Meeting and provide a presentation on cyanobacteria.

**NH RIVERS MANAGEMENT ADVISORY COMMITTEE:** Commissioner Hodgdon.

Commissioner C. Hodgdon reported that the committee would be meeting in January 2024

**SEARCH COMMITTEE:** Commissioners: M. Hodgson, Chair: Commissioners: E. Stohl, R. Green, J. Caveney & C. Hodgdon.

Chairman M. Hodgson reported that there has been a search committee assembled to start the search for the new Executive Director. She reported that there would be a committee meeting after the holidays to put together the process and stated that there would be open transparency to the full Commission all along the way.

**OLD BUSINESS:** Commissioner J. Caveney clarified his comments made last month relative to the Slalom Waterski Course on Swanzey Lake, a prominent trout fishery in Cheshire County. He stated that his goal was to send a letter requesting The Fish & Game Department have a meeting with Marine Patrol regarding the slalom waterski permitting process and potential effects to other people recreating on the lake.

**NEW BUSINESS:**

**COMMISSIONERS REPORTS:** Commissioners will report on their recent activities as it relates to Fish & Game Commission duties and responsibilities. This is an informational item only.

**DIRECTOR'S REPORT:**

He reported that he attended the NH Wildlife Federation Board of Director's Meeting and discussed last year's legislation.

He further reported that NH would be hosting the 2025 Northeast Association of Fish & Wildlife Agencies Annual Meeting. He reported that he expects the conference to be held at the Omni Mount Washington Resort, in Bretton Woods, NH.

In closing, he reported that the Law Enforcement Division has requested that the Director commit \$52,000 of Fish & Game Funds for pertinent repairs to the dock in New Castle, NH.

**CALL TO THE PUBLIC:**

Representative Kathryn Harvey, (District 6-Cheshire), reported that she was disappointed that the Commission did not decide to support her bill. She stated that she was willing to amend some of the language that Commissioner R. Green does not support. She stated that the Commission is under constant criticism that not everyone (non-consumptive users) are being recognized and heard. She stated, "There has to be a way to solve this. This bill allows outside organizations to submit the name of a nominee for Commissioners seats when there is a vacancy. I urge you to think about this problem, a change or two would offset the controversy. This issue is not going to go away!"

Steve Angers, Center Conway, NH, stated, "That is super great news & progress, updating our fish hatcheries! I cannot stress enough on the importance of effective hatcheries."

Kristina Snyder, Chester, NH, stated that she appreciated the Commission's position on the squirrel bill. She stated, "We hear a lot about tradition and what it means, what once was acceptable 100 years ago, is not acceptable today." She spoke how things progress/change through culture and society. She encouraged the Commission to reconsider Representative Harvey's bill, as you are all one voice, saying the same thing. "We need change, different outlooks & perspectives, to have a healthy discussion."

Tyson Morrill, Laconia, NH, thanked the Commission for their hard work on taking positions on the lengthy legislation list.

Paula Tracey, In Depth Magazine, reported that she would start attending and covering Commission Meetings, in addition to the upcoming Biennial Hearings.

Linda Dionne, Raymond, NH, stated that she was disappointed with Commissioner A. J. DeRosa for supporting hound hunting of coyotes. She stated, "The Native American people's tradition was to use the entire animal, they did not hunt coyote for fun". She further expressed her disappointment with not being able to provide public comment in the Legislative Committee meetings. Representative Harvey explained to Linda that the Commission's process was legal, and was how the Legislature conducts their committee meetings, as well.

Commissioner M. Hodgson responded to Linda and informed her that she was her Commissioner, and would be happy to be the portal to relay information to the Commission on her behalf, or answer any questions Linda may have.

Linda thanked Commissioner Hodgson and stated that she has been helpful in the past.

Julie Sinclair, Newmarket, NH, stated, "In the spirit that you make decisions regularly, you should think about all of New Hampshire's constituents, not just hunters or fishermen. You should also consider what communities want, as people want to do other things to recreate, as well. I encourage you to start thinking about each other and be a little more modern."

Chairman E. Stohl announced that the Executive Director Search Committee would be having a non-public meeting with legal counsel after the Commissioner Meeting.

Commissioner B. Temple inquired if the meeting was for the full Commission.

Chairman E. Stohl responded that the meeting was for Search Committee members only.

At this time, 3:31 p.m., Commissioner S. Price moved to adjourn and Commissioner C. Hodgdon seconded. The vote was unanimous in the affirmative.

---

Eric Stohl, Chairman  
NH Fish & Game Commission